



Pressure vessel (Pressure Level Control)

Pressure, level and instrumentation control study system

Module 5 (RP10)

Pressure vessel (Pressure/Level) at a glance

Sections

- ✓ Electrical engineering, Industrial maintenance, Automation, Regulation....

Educational activities

- ✓ Study of the different measurement principles (pressure, level, etc.)
- ✓ Calibration of the equipment used
- ✓ Identification of the system in BO, BF
- ✓ Simple pressure control (PID action study)
- ✓ Study of sequential operation, filling, emptying

Specific components

- ✓ Level measurements □ Capacitive probe
- ✓ Pressure measurements □ Relative pressure
- ✓ Valves □ Solenoid valves, proportional valves
- ✓ Storage □ Stainless steel pressure vessels
- ✓ Process control Controller, PID PLC, SNCC

Highlights

- ✓ Three types of commands can be used
- ✓ Ideal product for the study of industrial instrumentation and pressure and level control
- ✓ System based on a real application (Pressure vessel before bottling in a soda production line)

Related products

- ✓ RC10: Communicating Industrial Controller Module
- ✓ RC21: PLC module with PID and Touch Panel (Schneider M340 version with 16E/16S TOR - 8E ANA - 4S ANA + Ethernet TCP/IP + Web Server + CANopen Bus)
- ✓ RC31: PLC Module with PID and Touch Panel (Siemens S7-1500 version with 8E/8S digital - 24E ANA, of which 4 HART - 20S ANA + Ethernet TCP/IP)
- ✓ RC12: Digital Control System Module
- ✓ RC40: Pressure calibrator with pneumatic pump
- ✓ RC41: Calibrator for RTD temperature sensors (Pt100, PT1000, ...)
- ✓ RC42: Calibrator for Thermocouple (Tc) Temperature Sensors
- ✓ RM13: Option - 0/4-20 mA Current Loop Calibrator

References

- ✓ RP10: Pressure vessel (Pressure/Level)
- ✓ RL10: System Power and Safety Cabinet (Can be used with one or more systems)
- ✓ RM10: Option: Diaphragm for pressure and flow measurement
- ✓ RM11: Option: 4-20mA/Hart pressure sensor

Features

- ✓ L/ W/ H (with RL10 power supply unit): 920 x 1000 x 2230mm
- ✓ Electrical power: 240Vac - 50 Hz single phase (RL10 - System Power and Safety Box)
- ✓ Weight (with RL10 power supply): 160kg

BTS CIRA - BTS ME - Bac Pro Me

Grandes thématiques

Control - Servo control Instrumentation
Measurement - Maintenance



Module 5 (RP10)
Technical description
Functional description

✓ In an industrial soda manufacturing and production system, it is necessary to adapt the carbonation process to the bottling unit (manufacturing, packaging, batch management, etc.). To do this, it is necessary to set up a storage tank for the carbonated product under CO₂ pressure. This is to guarantee a perfectly carbonated product during bottling.

✓ Therefore, the pressure regulation inside this buffer tank must be precisely controlled so as not to let the product de-gas or over-carbonate the product before bottling.

Products used: CO₂ + Water/Syrup mixture (or only air in case of simple pressure regulation)

Set variable: Pressure in the vessel

Control variable: Gas flow rate "CO₂" (or Air in case of simple pressure regulation)

Disturbance variables: Liquid level in the tank, ambient temperature, opening/closing of the tank outlet, etc.

How it works

✓ Simple pressure regulation without liquid in the tank:

- The tank is supplied with air from the facility's network via the first flow control valve (Supply). This valve is used to regulate the air flow to the tank.
- The second flow control valve or leakage valve is used to disrupt the pressure regulation in the vessel by controlling the gas outlet flow (Event).

Pressure regulation with liquid in the tank :

- The tank is continuously supplied with liquid. When a sufficient level of liquid is reached in the tank (adjustable threshold), the pressure control in the tank starts with the aim of maintaining the defined pressure setpoint.
- A bottling simulation is ensured by the cyclic opening/closing of a solenoid valve placed at the tank outlet (configurable operating cycle).
- The pressure in the storage tank is then maintained by controlling the two solenoid valves (one for the supply and the other for the discharge of the gas).
- The regulation can be "Simple" (independent control of the two electrovalves) or "Complex" (Split Range control).

✓ To be noted:

- The module can be operated as a stand-alone unit using only air and water or with CO₂ + Water/Syrup mix when used in conjunction with other Reguflex modules.
- The pressure and level safety on the tank is ensured by limit switches integrated in the various sensors (level/pressure) as well as by two safety valves placed directly on the tank.

CO2 supply

This module is supplied with CO₂, from a standard storage bottle ("CarboPub" bottle), the outlet pressure of the bottle varies between 80 and 50 bar. A regulator and a heater are integrated on this CO₂ bottle.

Sockets and loose fittings

There are "free" tappings on the pipework to add various sensors. Students can calibrate, set up and test different sensors on the existing process.

Electricity, water and air supply

✓ The power supply is provided by the RL10 power supply box (one RL10 box can supply up to 5 Reguflex systems).

✓ The air and water supply must be provided from the establishment's water and air supply (max. P. 6 bar).

Connection to other Reguflex systems

✓ This module can be connected to one of the following systems to implement all or part of the manufacturing process:

- Module n°1 (RN10) - Buffer tank (Level/Flow): Study system for level, flow and instrumentation control
 - Module N°2 (RD10) - Dosing (Flow/Ratio) : Flow control study system, ratio and instrumentation.
 - Module N°3 (RT10) - Refrigeration (Flow/Temperature) : Study system for temperature control (Cooling), flow and instrumentation.
 - Module N°4 (RG10) Carbonation (Flow/Pressure): Carbonation of a liquid with measurement of flow, pressure and temperature.
- ✓ It can be operated by three types of controls:
- Industrial Controller Module (RC10) : Study of industrial PID single-loop and/or dual-loop controllers
 - Industrial Controller Module (RC21/RC31): Study of Industrial Controllers in PID regulation
 - DCS Module (RC12) : Study of Digital Control Systems
- ✓ Process supervision is possible:
- Using the WinnCC Flexible environment (RC31)
 - Using the Touch Panel (RC21)

Communication

The "4-20mA/Hart pressure sensor" option (RM11) allows control loops to be implemented via a transmitter communicating via a fieldbus HART protocol.

Technical description

Module 5 (RP10)

> IT Scheme

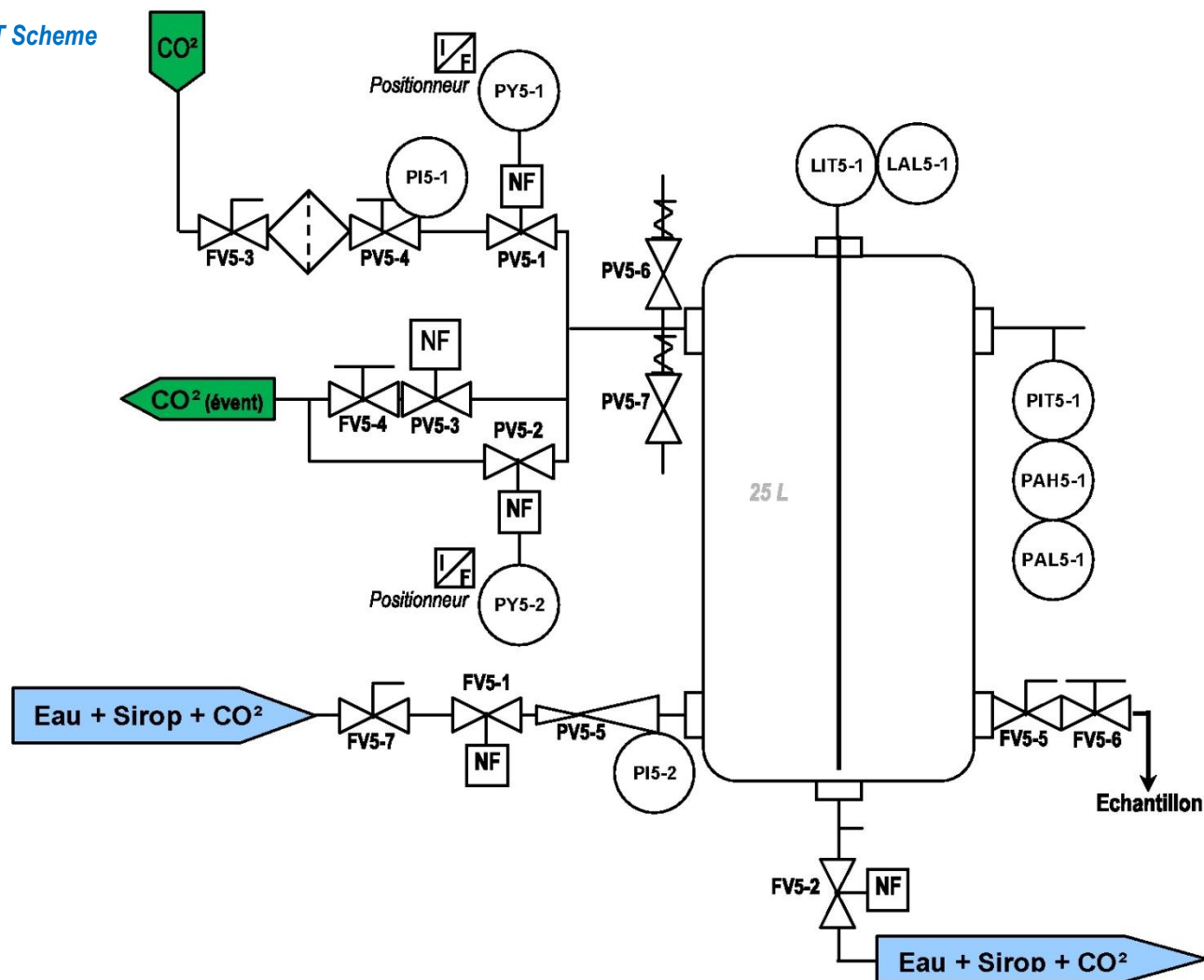

- FV5-1: Solenoid valve for liquid inlet ("Normally Closed" valve - 24 Vdc)
- FV5-2: Solenoid valve for liquid withdrawal ("Normally Closed" valve - 24 Vdc)
- FV5-3: ¼ turn manual shut-off valve
- FV5-4: Manual air flow control valve
- FV5-5: Manual ¼ turn ball valve with full bore
- FV5-6: Tap for sampling finished product
- FV5-7: Manual ¼ turn ball valve with full bore
- LAL5-1: Threshold relay (24 Vdc discrete contacts)
- LIT5-1: Capacitive Level Transmitter with Display (Capacitive Channel - 4-20 mA)
- PV5-1: Control valve for gas injection into the tank (Normally Closed Valve)
- PV5-2: Control valve for exhausting the gas contained in the "vent" tank (Normally Closed Valve)
- PV5-3: Solenoid valve for leak simulation (Normally Closed Valve - 24 Vdc)
- PV5-4 / PI5-1: Manual pressure regulator with display (0-10 bar)
- PV5-5 / PI5-2: Pressure relief valve with downstream pressure indicators
- PV5-6: Safety valve for excess pressure in the tank (7 bar)
- PV5-7: Vacuum breaker valve for vacuum in the tank
- PIT5-1 / PAL5-1 / PAH5-1 : Pressure transmitter with display + Alarm contacts for "high" and "low" pressure detection (24Vdc digital signal)
- PY5-1: Current/Frequency Positioner "I/F" for Gas Pressure Control Valve (4-20 mA)
- PY5-2: Current/Frequency Positioner "I/F" for Gas Pressure Control Valve (4-20 mA)

**Module 5 (RP10)**Pedagogical approach**Educational activities**

- ✓ Study of the different measurement principles (pressure, level, vibrating plate)
- ✓ Calibration of the equipment used
- ✓ System identification
- ✓ Study of the control valve (direction of action, intrinsic characteristic, installed characteristic)
- ✓ Simple pressure control (PID action study)
- ✓ Study of sequential operation, filling, emptying
- ✓ Split range control

Examples of Practical Work offered by ERM

- ✓ TP1 Generic Regulflex: Methods for identifying "Stable" and "Integrating" (Unstable) systems
 - BROIDA's method
 - ZIEGLER NICHOLS method
 - Empirical method or "tuner" method (successive approaches)
- ✓ TP2 Generic Regulflex: "Volumetric" and "Mass" flow measurement and control
 - Type of measure
 - Method, Calculations...
- ✓ TP3 Generic Regulflex: Sizing and implementation of depressors
- ✓ TP4 Generic Regulflex: Complex regulations that can be implemented on the system (Cascades, Predictive...)
- ✓ TP5: Study of Pressure Regulation