

Food refrigeration (Flow Temperature Control)

Study system (food refrigeration) of temperature control, flow and instrumentation

Module N°3 (RT10)

Food refrigeration (Flow Temperature Control) at a glance

Sections

- ✓Electrical engineering, Industrial maintenance, Automation, Regulation...

Educational activities

- ✓Study of the different measurement principles
- ✓System identification (Use of different methods)
- ✓Simple temperature control (study of P,I,D actions)
- ✓Mixed or predictive control
- ✓Speed variation
- ✓Heat balances
- ✓Power calculation, heat exchanger sizing

Specific components

- ✓Flow measurements □ Rotameter, Thermal mass flow meter
- ✓Temperature measurements □ PT100, Thermocouple J, Thermocouple K, Conditioners, ...
- ✓Pumps □ Volumetric electric pump with speed variation
- ✓Converter □ Resistance/Current
- ✓Process components □ Plate heat exchangers
- ✓Industrial refrigeration □ Condensing unit, Expansion valve, Evaporator, Pressure switches, Thermostats, ...
- ✓Communication & Fieldbus (Option)
- ✓Process control □ Controller, PID PLC, SNCC

Highlights

- ✓Three types of commands can be used
- ✓Ideal product for industrial instrumentation and temperature and flow control
- ✓Study of the refrigeration circuit for chilled water production
- ✓System based on a real application (chilled water production of a soda production line)

Related products

- ✓RC10: Communicating Industrial Controller Module
- ✓RC21: PLC module with PID and Touch Panel (Schneider M340 version with 16E/16S TOR - 8E ANA - 4S ANA + Ethernet TCP/IP + Web Server + CANopen Bus)
- ✓RC31: PLC Module with PID and Touch Panel (Siemens S7-1500 version with 8E/8S digital - 24E ANA, of which 4 HART - 20S ANA + Ethernet TCP/IP)
- ✓RC12: Digital Control System Module
- ✓RC40: Pressure calibrator with pneumatic pump
- ✓RC41: Calibrator for RTD temperature sensors (Pt100, PT1000, ...)
- ✓RC42: Calibrator for Thermocouple (Tc) Temperature Sensors
- ✓RM13: Option - 0/4-20 mA Current Loop Calibrator

References

- ✓RT10: In-line Refrigeration (Flow Temperature Control)
- ✓: Option: Diaphragm for pressure and flow measurement
- ✓RL10: System Power and Safety Cabinet (Can be used with one or more systems)
- ✓RT11: Temperature measurement option for heat balances (3 additional sensors)
- ✓RT12: Flow control valve option
- ✓RM10RM11: Option: 4-20mA/Hart pressure sensor

Features

- ✓L/ W/ H (with RL10 power supply unit): 920 x 1000 x 2230mm
- ✓Electrical power: 240Vac - 50 Hz single phase (RL10 - System Power and Safety Box)
- ✓Weight (with RL10 power supply): 240kg
- ✓This system is accompanied by a technical and educational file

BTS CIRA - BTS ME - Bac Pro Me

Grandes thématiques

Control - Servo control Instrumentation
Measurement - Maintenance



**Module N°3 (RT10)****Technical description****Functional description**

✓ This module brings a liquid (e.g. Water+Syrup mixture) to a temperature of about 5°C before the carbonation stage necessary for the manufacture of soda. This cooling step allows to limit the pressure of CO₂ insertion in the liquid. All heat exchanges are carried out using plate heat exchangers

Products used

- Water + syrup (or Water) mixture
- Glycol water (40%)
- Refrigerant R452A.

Set variable: Temperature of the liquid at the module outlet

Control variable: Brine flow rate

Disturbance variables

- Flow rate of the water+syrup mixture (or water) at the inlet,
- Temperature of the water+syrup (or water) mixture at the inlet ,
- Ambient temperature

How it works

✓ Simple temperature control :
• The water + syrup mixture from the previous module entering the system forms a first fluid circuit. A second fluid circuit (glycol water) is used to cool the water+syrup mixture.
• The two liquids pass through a plate heat exchanger. The temperature of the water+syrup mixture at the exchanger outlet (fluid to be cooled) is then measured. Depending on the temperature of the water+syrup mixture, the flow rate of the cooling circuit (glycol water) is adjusted to obtain and/or maintain the set temperature.

Stitches and loose connections

✓ There are "free" tapings on the pipework to add various sensors. Students can calibrate, set up and test different sensors on the existing process.

Electricity, water and air supply

✓ The power supply is provided by the RL10 power supply box (one RL10 box can supply up to 5 Regulflex systems).
✓ The air and water supply must be provided from the establishment's water and air supply (max. P. 6 bar).

Temperature measurement for heat balances (option RT11)

Three additional temperature sensors (Thermocouple J, Thermocouple K, PT1000) can be used to study different scaling according to the type of temperature sensor and to perform a heat balance on the temperature exchange performed on the system.

Control valve (option RT12)

A control valve placed at the input of the module can be implemented to allow autonomous use of the RT10. This option can also be used for: water flow control or cascade control

Connection to other Regulflex systems

- ✓ This module can be connected to one of the following systems to implement all or part of the manufacturing process:
- Module n°1 (RN10) - Buffer tank (Level/Flow): Study system for level, flow and instrumentation control
 - Module N°2 (RD10) - Dosing (Flow/Ratio) : Flow control study system, ratio and instrumentation.
 - Module N°4 (RG10) Carbonation (Flow/Pressure): Carbonation of a liquid with measurement of flow, pressure and temperature.
 - Module N°5 (RP10) Pressure vessel (Level/Pressure): Study system (pressure storage) of pressure regulation, level and instrumentation
- ✓ It can be operated by three types of controls:
- Industrial Controller Module (RC10) : Study of industrial PID single-loop and/or dual-loop controllers
 - Industrial Controller Module (RC21/RC31): Study of Industrial Controllers in PID regulation
 - DCS Module (RC12) : Study of Digital Control Systems
- ✓ Process supervision is possible:
- Using the WinnCC Flexible environment (RC31)
 - Using the Touch Panel (RC21)

Communication

The option "4-20mA/Hart pressure sensor" (RM11) allows to realize control loops via a transmitter communicating through a fieldbus HART protocol.



Technical description

Heat exchange

- ✓ The temperature control module integrates a self-contained chiller to generate a chilled water circuit (40% glycol water). This chilled water is cooled to -2°C as it passes through the evaporator of the chiller to bring the temperature of the water+syrup mixture to between 5 and 10°C .
- ✓ Generally speaking, it is important to note that cooling the water+syrup mixture facilitates its carbonation.
- ✓ The second exchange circuit (Evaporator) is necessary to avoid contact between the refrigerant and the water+syrup mixture.

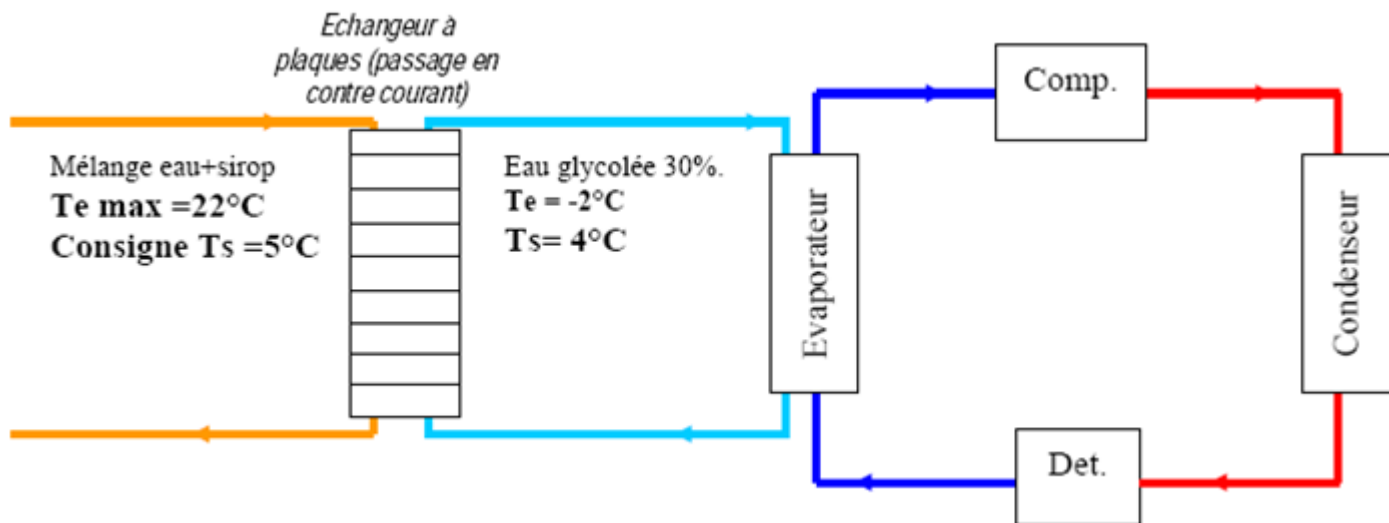



Module N°3 (RT10)

Technical description

➤ IT Scheme

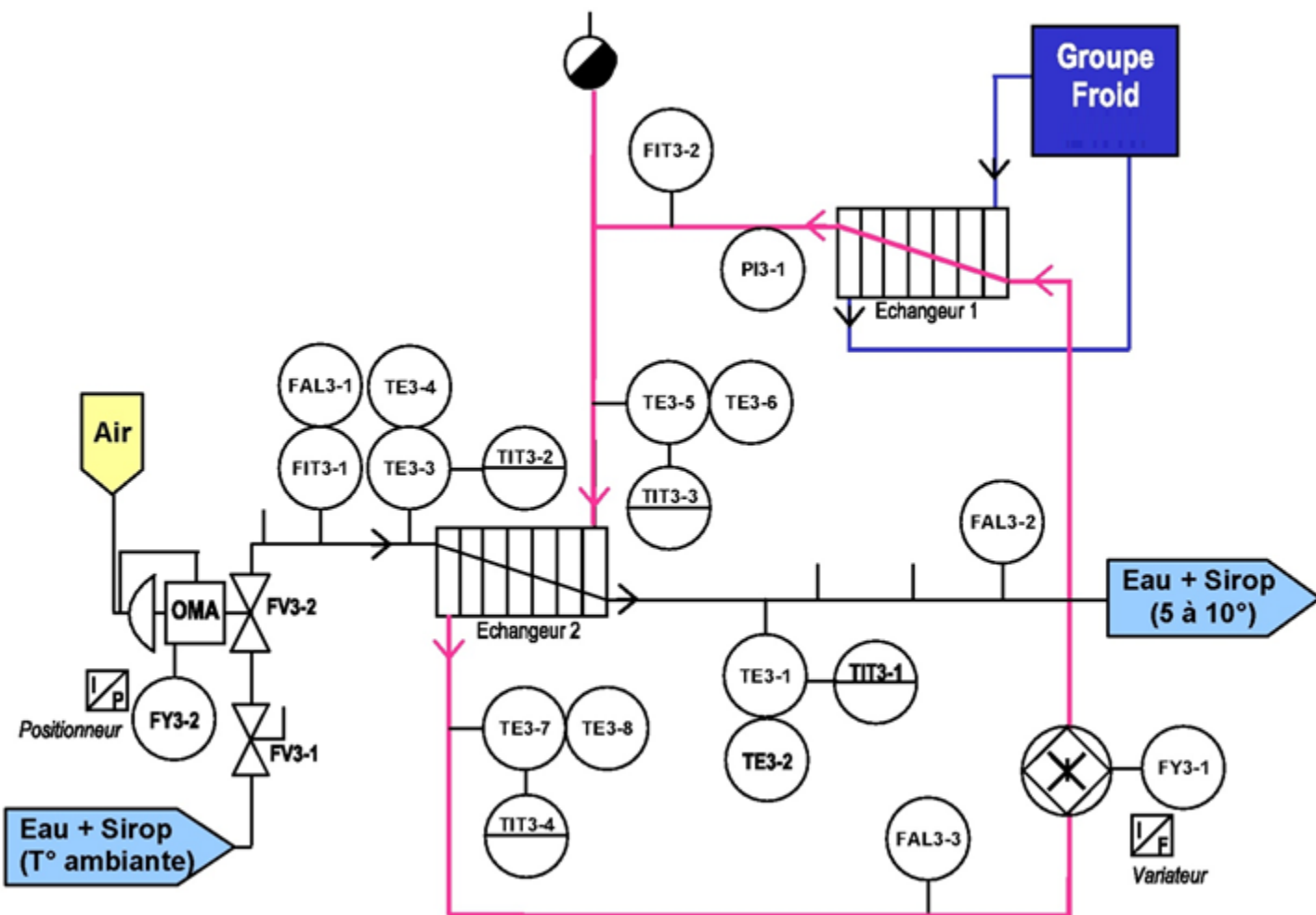

- FAL3-2: Float flow sensor ("FlowSwitch" - Detection setting: 1.5 l/min)
- FAL3-3: Paddle flow sensor ("FlowSwitch" - detection setting 4 l/min)
- FIT3-1/FAL3-1: Indicator Mass Flow Transmitter (4-20 mA Signal) / 24 Vdc Discrete Alarm Contact
- FIT3-2: "Vortex" Flow Transmitter Indicator (4-20 mA signal)
- FV3-1: 1/4 turn manual ball valve with full bore
- FY3-1: Frequency inverter for brine circulation pump control (4-20 mA signal / 0 to 8l/min)
- PI3-1: Pressure indicator (0-10 bar)
- TE3-1/TE3-2: "Duplex" temperature sensor (PT100 - 3 wires)
- TE3-3/TE3-4 (OPTION): "Duplex" temperature sensor (PT1000 - 3 wires)
- TE3-5/TE3-6 (OPTION): "Duplex" temperature sensor (Thermocouple J - 3 wires)
- TE3-7/TE3-8 (OPTION): "Duplex" temperature sensor (K thermocouple - 3 wires)
- TIT3-1: Digital Temperature Indicator Transmitter (4-20 mA signal)
- TIT3-2 (OPTION): Digital Temperature Indicator Transmitter (4-20 mA signal)
- TIT3-3 (OPTION): Digital Temperature Indicator Transmitter (4-20 mA signal)
- TIT3-4 (OPTION): Digital Temperature Indicator Transmitter (4-20 mA signal)
- FV3-2 (OPTION) : Pneumatic flow control valve ("Open by Lack of Air" valve)
- FY3-2 (OPTION) : Current/Pressure positioner for flow control valve with position feedback (4-20 mA signal)



Module N°3 (RT10)

Pedagogical approach**Educational activities**

- ✓ Study of the different principles of measurement.
- ✓ System identification (Use of different methods)
- ✓ Study of a circulation pump (Control, Servo control, Flow rate, ...).
- ✓ Simple temperature control (study of P,I,D actions)
- ✓ Trend (or mixed) control.
- ✓ Heat balances.
- ✓ Calculation of cooling capacities, sizing of exchangers.

Examples of practical work proposed by ERM

- ✓ TP1 Generic Regulflex: Methods for identifying and controlling "Stable" and "Integrating" systems
BROIDA's method
ZIEGLER NICHOLS method
Empirical method or "tuner" method (successive approaches)
- ✓ TP2 Generic Regulflex: Principle of "Volumetric" and "Massive" flow measurement and regulation
Type of measurement, Method, Calculations...
- ✓ TP3 Generic Regulflex: Sizing and implementation of depressors
- ✓ TP4 Generic Regulflex: Complex regulations that can be implemented on the system (Cascades, Predictive...)
- ✓ TP5: Study of Temperature Control
- ✓ TP6: Identification and operating principle of refrigeration production
- ✓ TP7: Thermal and thermodynamic measurements and operation