

Dosing (Flow control Ratio)

Flow control study system, report and instrumentation

Module N°2 (RD10)

Dosing (Flow Control Ratio) at a glance

- **Sec...**
 - ✓ Electrical engineering, Industrial maintenance, Automation, Control, Water professions...
- **Educational activities**
 - ✓ Analogue and digital measurements
 - ✓ System identification
 - ✓ Study of a metering pump in a control system.
 - ✓ Ratio regulation (calculation of the coefficient according to the flow rates, observation of saturation at high flow rates, etc.).
- **Specific components**
 - ✓ Level measurements (Low Threshold) □ Ultrasonic sensor
 - ✓ Flow measurements □ Rotameter, Vane flow meter
 - ✓ Various measurements □ Temperature, Concentration, Sugar content (° Brix)
 - ✓ Pumps □ Volumetric diaphragm dosing pump
 - ✓ Valve □ Electropneumatic control valve with integrated positioner and position feedback
 - ✓ Process control (□ Regulator, PLC, SNCC)
- **Highlights**
 - ✓ Three types of commands can be used
 - ✓ Ideal product for the study of industrial instrumentation, flow control on liquids.
 - ✓ System based on a real application (Syrup dosing on a soft drink production line)
- **Related products**
 - ✓ RC10: Communicating Industrial Controller Module
 - ✓ RC21: PLC module with PID and Touch Panel (Schneider M340 version with 16E/16S TOR - 8E ANA - 4S ANA + Ethernet TCP/IP + Web Server + CANopen Bus)
 - ✓ RC31: PLC Module with PID and Touch Panel (Siemens S7-1500 version with 8E/8S digital - 24E ANA, of which 4 HART - 20S ANA + Ethernet TCP/IP)
 - ✓ RC12: Digital Control System Module
 - ✓ RC40: Pressure calibrator with pneumatic pump
 - ✓ RC41: Calibrator for RTD temperature sensors (Pt100, PT1000, ...)
 - ✓ RC42: Calibrator for Thermocouple (Tc) Temperature Sensors
 - ✓ RM13: Option - 0/4-20 mA Current Loop Calibrator
- **Features**
 - ✓ L/ W/ H (with RL10 power supply unit): 920 x 1000 x 2230mm
 - ✓ Electrical power: 240Vac - 50 Hz single phase (RL10 - System Power and Safety Box)
 - ✓ Weight (with RL10 power supply): 200kg

BTS CIRA - BTS ME - Bac Pro Me

Grandes thématiques

Control - Servo control Instrumentation
Measurement - Maintenance



References

- ✓ RD10: Dosing (Flow control Ratio)
- ✓ RL10: System Power and Safety Cabinet (Can be used with one or more systems)
- ✓ RD11: Control valve option (For complex controls)
- ✓ RD12: Optional Indicator Density (Brix) and Temperature Transmitter
- ✓ RM10: Option: Diaphragm for pressure and flow measurement
- ✓ RM11: Option: 4-20mA/Hart pressure sensor



Module N°2 (RD10)

Functional description

- ✓ This module allows the implementation of different regulation strategies on liquids in order to carry out a dosage (Water + syrup (or colouring) mixture). The injection of syrup (or dye) into the water is carried out using a volumetric diaphragm dosing pump. The system also includes an optional electro-pneumatic control valve with integrated positioner.
- ✓ The syrup is stored in a tank whose low level (low threshold) is monitored with an ultrasonic sensor (measurement without contact with the product).
- ✓ Simple flow control or proportion/density control can be implemented on the system. The syrup flow rate corresponds to the flow rate to be controlled. The water flow rate is the pilot flow rate (also called "free flow rate").

- **Product used:** *Water, syrup (or dye),*
- **Set value:** *Injection rate of syrup (or dye)*
- **Control variable :** *Water flow rate*
- **Disturbance variables:** *Variation of water flow*

How it works

- ✓ Proportional control.
 - This type of regulation aims to control a flow Q_a to another "free" flow Q_l by imposing a fixed proportionality factor K_d between these two flows. In this module, the syrup flow rate is the flow rate to be controlled and the water flow rate represents the free flow rate (or pilot).
 - A solution using a dosing pump is proposed. The water flow rate is measured, and the syrup injection rate (dosing) is adapted according to a predefined ratio.
 - In case of high flow rates, the limits of the proportion can be shown ("saturation" phenomenon).

Storage of syrup (or dye)

The syrup (or dye) is stored in a closed container and connected to the dosing pump. A digital level sensor detects the low level of storage (Detection for Alarm and Dosing Stop).

Control valve (option RD11)

A control valve placed at the inlet of the module can be implemented to allow autonomous use of the RD10. This option can also be used for: water flow regulation or water ratio regulation.

Density transmission (option RD12)

A density transmitter (measurement of the sugar level °Brix) can be used to create: a control loop measuring the sugar level of the water + syrup solution and acting on the dosing pump.

Sockets and loose fittings :

There are "free" tappings on the pipework to add various sensors. Students can calibrate, set up and test different sensors on the existing process.

Electricity, water and air supply

- ✓ The power supply is provided by the RL10 power supply box (one RL10 box can supply up to 5 Regulflex systems).
- ✓ The air and water supply must be provided from the establishment's water and air supply (max. P. 6 bar).

Connection to other Regulflex systems

- ✓ This module can be connected to one of the following systems to implement all or part of the manufacturing process:
 - Module n°1 (RN10) - Buffer tank (Level/Flow): Study system for level, flow and instrumentation control
 - Module N°3 (RT10) - Refrigeration (Flow/Temperature) : Study system for temperature control (Cooling), flow and instrumentation.
 - Module N°4 (RG10) Carbonation (Flow/Pressure): Carbonation of a liquid with measurement of flow, pressure and temperature.
 - Module N°5 (RP10) Pressure vessel (Pressure/level): Study system (pressure storage) of pressure regulation, level and instrumentation
- ✓ It can be operated by three types of controls:
 - Industrial Controller Module (RC10) : Study of industrial PID single-loop and/or dual-loop controllers
 - Industrial Controller Module (RC21/RC31): Study of Industrial Controllers in PID regulation
 - DCS Module (RC12) : Study of Digital Control Systems
- ✓ Process supervision is possible:
 - Using the WinnCC Flexible environment (RC31)
 - Using the Touch Panel (RC21)

Communication

The "4-20mA/Hart pressure sensor" option (RM11) allows control loops to be implemented via a transmitter communicating via a fieldbus HART protocol.



Module N°2 (RD10)

Technical description

➤ IT Scheme

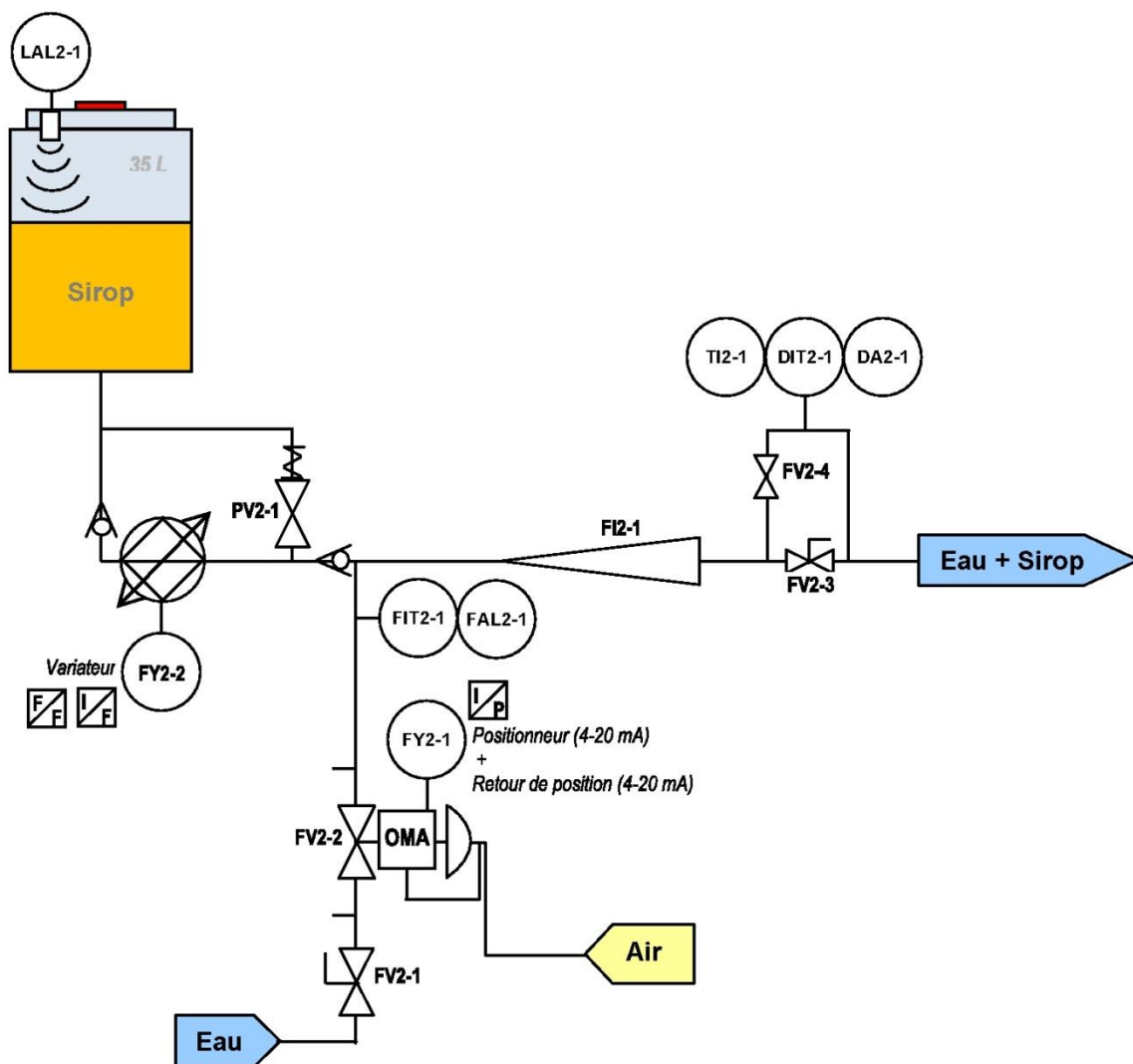

DIT2-1/DA2-1/TI2-1 (OPTION): Density transmitter indicator "Brix" (4-20 mA signal) + Alarm contact (24 Vdc digital signal) + "C" temperature indicator

FI2-1: "Rotameter" float flow indicator (0 to 500 l/h)

FIT2-1/FAL2-1: Flow Transmitter Indicator (Rotor Flow Meter 1-16l/min- 4-20 mA signal + Alarm contact for "low" flow detection (24Vdc digital signal)

FV2-1: 1/4 turn manual ball valve with full bore

FV2-2 (OPTION) : Pneumatic flow control valve ("Open by Lack of Air" valve)

FV2-3: Manual needle valve

FV2-4 (OPTION): Mechanical flow regulator/limiter (2l/min Max.)

FY2-1 (OPTION) : Current/Pressure positioner for flow control valve with position feedback (4-20 mA signal)

FY2-2: Control electronics for dosing pump (4-20mA signal or digital via "relay")

LAL2-1: Ultrasonic level transmitter (24 Vdc digital signal)

PV2-1: Safety valve for syrup injection circuit (12 bar)

TI2-1 (OPTION): Temperature Indicator



Module No. 2 (RD10)

Pedagogical approach

Educational activities

- ✓ Study of the different principles of analogue and digital measurements
- ✓ Identification of the system in BO, BF
- ✓ Study of a metering pump in a control system.
- ✓ Ratio control (Calculation of the coefficient according to the flow rates, observation of saturation at high flow rates).

Examples of Practical Work offered by ERM

- ✓ TP1 Generic Regulflex: Methods for identifying and controlling "Stable" and "Integrating" systems
 - BROIDA's method
 - ZIEGLER NICHOLS method
 - Empirical method or "tuner" method (successive approaches)
- ✓ TP2 Generic Regulflex: Principle of "Volumetric" and "Massive" flow measurement and regulation
 - Type of measure
 - Method, Calculations...
- ✓ TP3 Generic Regulflex: Sizing and implementation of depressors
- ✓ TP4 Generic Regulflex: Complex regulations that can be implemented on the system (Cascades, Predictive...)
- ✓ TP5: Study of ratio control